

### General Specifications

#### Outdoor models

**PVI-3600-OUTD**

**PVI-3600-OUTD-F**

**PVI-2000-OUTD**

#### AURORA<sup>®</sup> BENEFITS

- Dual input section to process two strings with independent MPPT (3600W max models)
- IP65 (NEMA 4) ruggedized, completely sealed unit to stand the harshest environmental conditions
- High speed MPPT for real time power tracking and improved energy harvesting
- Compact size and high power density: 3000W (3600W max) of output power in a box just 420mm x 326mm x 141mm
- Front heatsink keeps the unit cleaner and more efficient over time
- Transformerless operation for highest efficiency: up to 96%
- Reverse polarity protection minimizes chance of damage due to mis-wiring
- High overload capability: works up to 3600W under most ambient conditions
- True Sine Wave Output
- Anti-islanding Protection
- Certified grid connected operation according to the international standards
- LCD Display on the front to monitor the main parameters
- Integrated Power Line Modem (PLM) for communication over AC wires
- Standard DC Multi-Contact terminals, screw terminals option available



#### HIGH PERFORMANCE REDEFINED

The revolutionary switching technology utilized in the Aurora inverter includes state-of-the-art for silicon Power Devices such as Silicon Carbide Diodes, CoolMOS™ and Insulated Gate Bi-polar Transistors (IGBT's) to reduce switching losses. Aurora has been designed with large de-rating criteria on all critical components, achieving an extremely robust and reliable inverter designed to last for 25 years and to deliver true maximum output power on a continuous basis. With this design concept we achieve peak efficiencies of over 96%. Total current harmonic distortion, on the other hand, is typically less than 1% through the use of high-frequency switching techniques. Another exclusive advantage is Aurora's two source circuit inputs, each with its own MPPT (Max Power Point Tracker) for installations with multiple arrays (available on the PVI-3600 model only).

#### BLOCK DIAGRAM AND TYPICAL EFFICIENCY

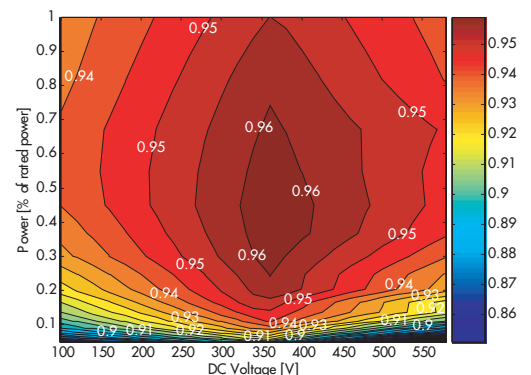
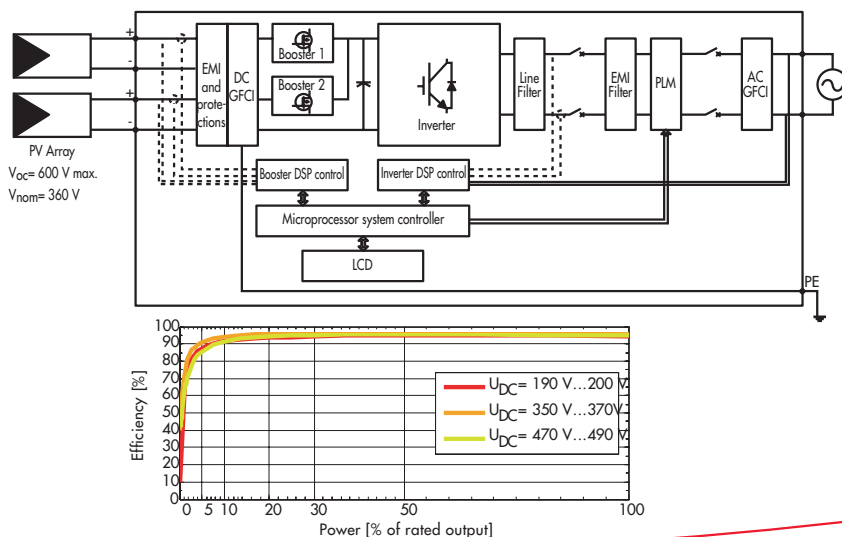

CHARACTERISTICS	PVI-2000-OUTD	PVI-3600-OUTD
Power Rating Ac [W]	2000	3600
Absolute Max Voltage range [Vdc]	0 to 600 (360 nominal)	
Max. Power Tracking Window range [Vdc]	90 to 580 (360 nominal)	
Array Configuration ( Max. Idc =10A for each channel )	One array	One or two arrays with common negative and independent MPPT
Nominal AC Voltage (Range) [Vrms]	Single-phase 185-264 (may vary to comply with regulations in each country)	
Nominal AC Frequency [Hz]	50/60	
Line Power Factor	1	
Maximum AC Line Current [Arms]	9	16
AC Current Distortion [%]	<2.5% THD at rated power with sinewave voltage	
Max Efficiency [%]	96 (Euro 95)	
Tare Losses [mW]	<200	
Operating Ambient Temperature [°C]	-25 to +60	
Enclosure Environmental Rating	IP65 / NEMA 4 X	
Relative Humidity	0-100% condensing	
Elevation	Derated above 6,600ft (2000m)	
Audible Noise [dBA]	< 40	
Size (height x width x depth) [mm]	420 x 326 x 141	
Weight [kg]	12	13

## MODEL SUMMARY

Model Number	Power
PVI-3600-OUTD	3600W
PVI-3600-OUTD-F (-F- with external fan)	3600W
PVI-2000-OUTD	2000W

## SMART CONTROLS

Aurora controls are DSP (Digital Signal Processor) based with sophisticated control and self-diagnostic algorithms. A LCD display shows the main operational parameters. Three LED's indicate the operating status.

## BEST IN CLASS COMMUNICATION CAPABILITIES

Aurora offers the best integrated Power Line Modem (PLM) communication available on the market. PLM allows monitoring of up to 63 units working in parallel for large installations without the need of extra wires, and allows data to flow to our optional external graphical LCD controller Aurora Easy Control or a PC via our Aurora PLMREC adaptation box. Aurora also comes with integrated RS485 communication link.

## STANDARDS AND CODES

Aurora inverters comply with standards set for grid-tied operation, safety and electromagnetic compatibility including: UL1741 (only PVI-3600-OUTD model), VDE0126, CEI 11-20 IV ed, DK5940, IEC 61683, IEC 61727, EN50081, EN50082, EN61000, CE certification.

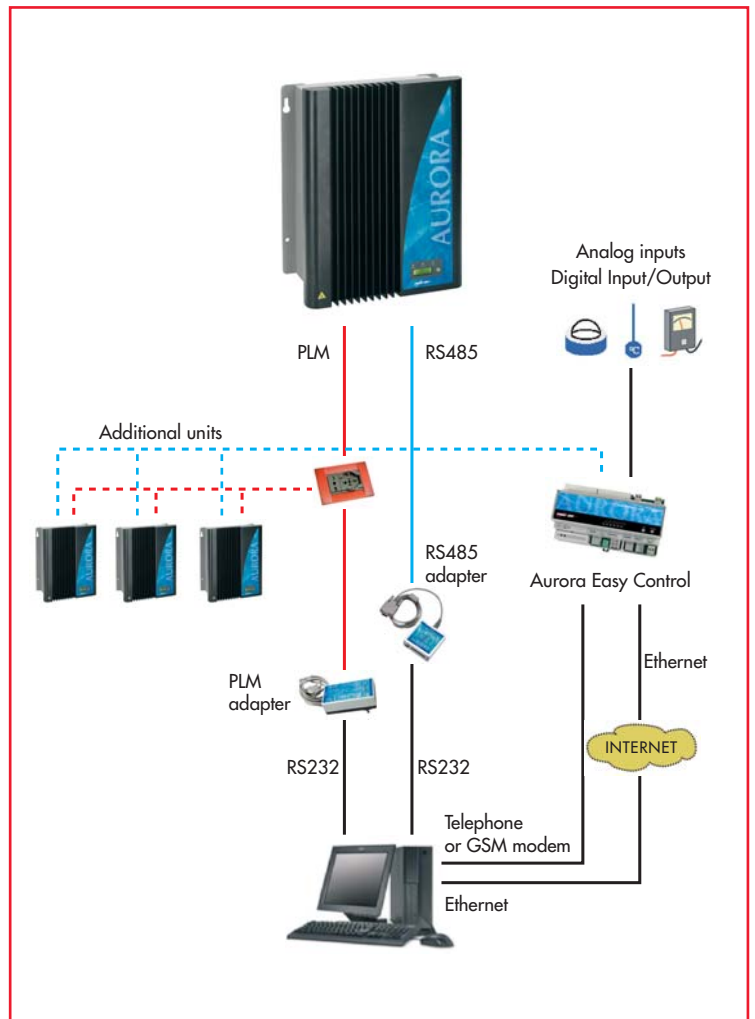

Rev. 1.5 - 12/04/07 - Aurora is a trademark by Power-One - Product is subject to technical improvements

**Europa**  
**Power-One Italy S.p.a.**  
Via S. Giorgio, 642  
52028 Terranuova Bracciolini, Arezzo, Italy  
Phone: (+39) 055 9195 1  
Fax: (+39) 055 9198 185  
aesales-eu@power-one.com

**North America**  
**Power-One Inc.**  
740 Calle Plano  
Camarillo, California - 93012-8583  
aesales-us@power-one.com